

STURMGESCHÜTZ IV sdkfz163

1/35 MILITARY MINIATURE SERIES



TAMIYA
TAMIYA PLASTIC MODEL CO.
628, OSHIKA, SHIZUOKA-CITY, JAPAN.

1.063100

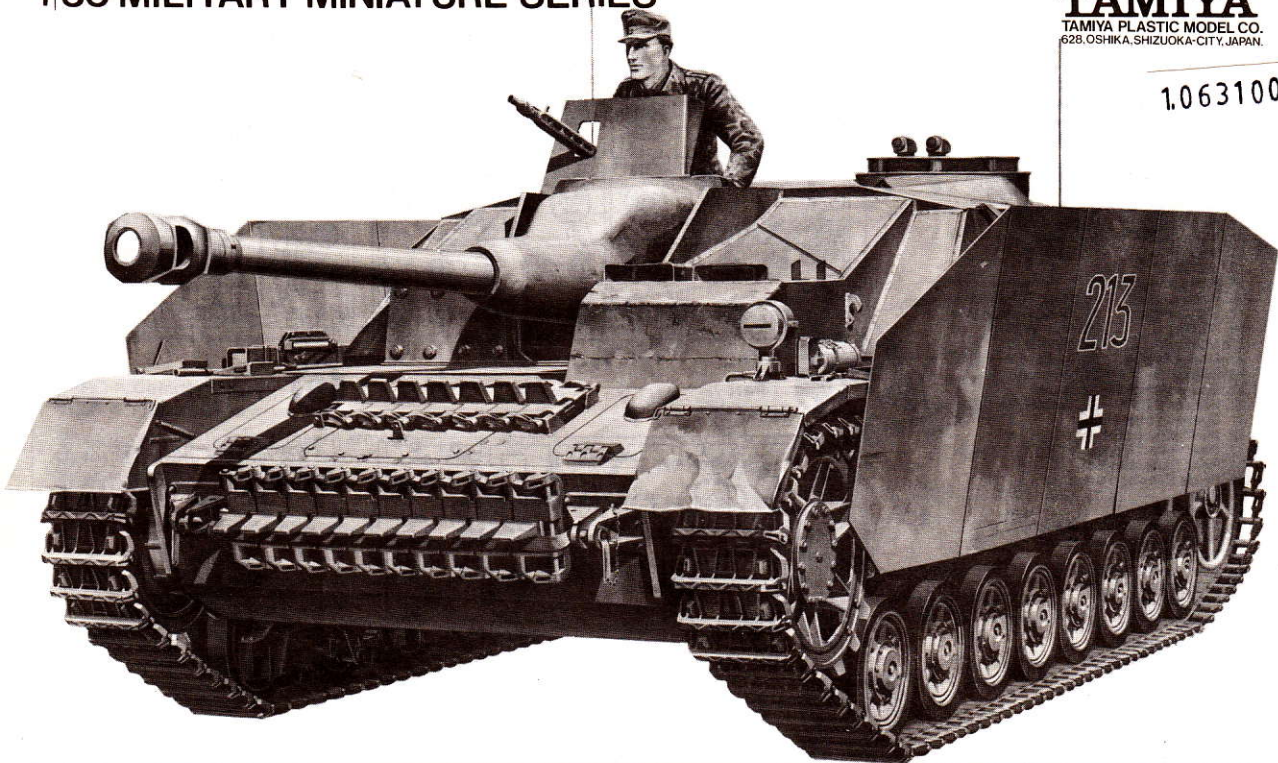

The Sturmgeschuetz (storm or assault gun) was developed in the 1936-39 period to provide armoured support for the infantry. This came about largely because the new tanks being produced were destined for the panzer (armoured) divisions. In a battlefield situation there was no guarantee that tanks from an armoured division would be available to support the infantry. Thus the idea of the assault gun regiment organic to an infantry division came about. The new assault gun developed was based on the Panzerkampfwagen III Designated Strumgeschuetze III, the assault gun had a low superstructure

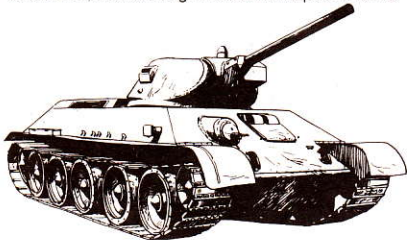

with its main armament mounted in the superstructure front and given limited traversers. Pre-production vehicles were battle-tested in the invasion of France in May 1940, and then ordered into large scale production. The original idea was for a vehicle able to give fire support for the infantry, but it was soon discovered that an anti-tank capability was even more important. Later models of the StuG III led to the StuG 40 in early 1942, a StuG III with either a 7.5 cm Sturmkanone 40 L/43 or (later) a Sturmkanone 40 L/48. In 1943 prouction of the PzKpfw III was phased out as being at the end of its development as a gun tank. Because of the great losses of tanks on the Russian front General Guderian suggested that StuG III vehicles be issued to tank divisions as they were cheaper, simpler and quicker to build than tanks. This would have created an even bigger increase in StuG III output which was already insufficient to meet demands. So it was decided in a conference with Hitler in November 1943 to use the chassis of the Panzerkampfwagen IV. The object was to use this new Strumgeschuetze IV for the panzer divisions. This would greatly simplify maintenance as the panzer divisions were all equipped with the Panzer IV tank. A prototype was ready

in a month, using a superstructure from StuG III production output. As the Panzer IV chassis was 46 cm longer, and 8 cm lower than the StuG III it was necessary to weld in an extra forward deckplate, and superstructure side strips, to fill the gaps. On the left front of the superstructure an armoured box (with two periscopes and a hatch) was built forward to cover the driving position. Production started in December 1943. Krupp-Gruson of Magdeburg the builders. Total production was about 1000 vehicles. StuG IVs equipped the third battalions of some tank regiments in place of tanks. Early models were on the PzKpfw IV Ausf H chassis but most were on the Ausf J chassis. Zimmerit anti-magnetic coating was common, and some had ferro-concrete added on the superstructure front for added protection. Crew: 4, combat weight 23 tons, top speed 24 mph (road), 15 mph (cross country), ammunition: 63 rds (AP 39, AP 40, HE), armour: 85 mm (max) 10 mm (min). Other details as PzIV.

Sturmgeschütze wurden zwischen 1936 und 1939 zur Unterstützung der Infanterie entwickelt, nachdem die neuen Panzer nur den Panzerdivisionen unterstellt waren.

Im Kampfangriff war es nicht sicher, ob Panzer von den Panzerdivisionen abgestellt werden konnten. Daher kam die Idee, Sturmgeschützabteilungen direkt der Infanterie einzugliedern.

Das neue Sturmgeschütz wurde auf dem Chassis des Panzer III entwickelt und offiziell Sturmgeschütz III bezwichnet, hatte einen niedrigen Aufbau und die Kanone einen beschränkten Schwenkbereich.

Im Frankreichfeldzug wurden im Mai 1940 bereits einige Prototypen eingesetzt - mit Erfolg - und so konnte die Produktion in grosser Stückzahl anlaufen. Vorgesehen war die Unterstützung der Infanterie, es wurde aber bald klar, dass die Panzerabwehr wichtiger war.

Spätere Ausführungen des Sturmgeschütz III führten zum StuG 40 Anfangs 1942, ein StuG III mit 7,5 cm Sturmkanone 40 L/43 oder (später) mit Sturmkanone 40 L/48.

1943 wurde die Produktion des Panzer III eingestellt, da eine weitere Entwicklung als Kanonenpanzer nicht mehr möglich war.

Durch den grossen Verlust an Panzern im Osten, schlug General Guderian vor, die Sturmgeschütze III in die Panzerdivisionen zu überstellen. Die Produktion war billiger, schneller und einfacher als

die der Panzer. Dadurch würde auch eine grössere Steigerung in den Stückzahlen möglich sein. Im November 1943 wurde in einer Besprechung mit Hitler beschlossen, das Fahrgestell des Panzer IV zu verwenden und als neues StuG IV den Panzerdivisionen zuzuführen. Auch die Unterhaltung und Reparaturen konnten vereinfacht werden.

Innerhalb eines Monats war ein Prototyp fertig unter Verwendung des normalen Aufbaus des StuG III.

Da das Fahrgestell des Panzer IV 46 länger und 8 cm niedriger war als das StuG III, musste eine zusätzliche vordere Deckplatte und an den Seiten Streifen eingeschweisst werden, um die Lücken zu füllen.

An der linken Frontseite des Aufbaues wurde zu Abdeckung des Fahrerstitzes ein gepanzerter Kasten aufgesetzt und mit 2 Winkelspiegel und Lukendeckel versehen.

Produktion lief im Dezember bei Krupp/Gruson in Magdeburg an und die gesamte Produktion erreichte ca 1000 Fahrzeuge. Anstelle der Panzer, wurden in einigen Panzerregimentern die 3. Bataillone mit Sturmgeschütz IV ausgerüstet. Die ersten StuG IV waren auf Pz IV Ausf. H Chassis, die weiteren auf Pz IV Ausf. J Chassis gebaut.

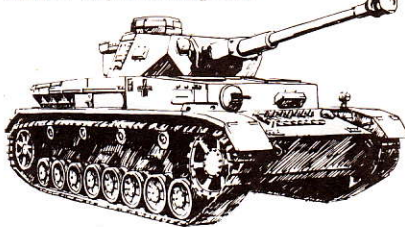

Zimmerit anti-magnetic Belag war üblich, jedoch wurde auch zum zusätzlichem Schutz der Front Eisenbeton verwendet.

Crew 4 Mann, Kampfgewicht 23 to, Strasse 38 km, Gelände 21 km, Munition 63 Granaten AP 39, AP40 HE, Panzerung Front 80 mm, Seite 30 mm, Heck 20 mm, Tank 430 Liter, Verbrauch Strasse 230 l, Gelände 340 l.

Weitere Details siehe Panzer IV

PARTS

A PARTS

1. Idler Wheels A
2. Idler Wheels B
3. Road Wheels A
4. Road Wheels B
5. Unnecessary
6. Final Cover Right
7. Upper Rollers A
8. Suspension Right
9. Drive Sprocket A
10. Drive Sprocket B
11. Upper Rollers B
12. Final Cover Left
13. Unnecessary
14. Suspension Left
- 15, 16, 17, 18. Unnecessary

B PARTS

1. Front Hook
2. Spare Wheel A
3. Ax
4. Nut Wrench
5. Air Intake
6. Hook A
7. Hook B
8. Spanner
9. Wire Cutter
10. Crank
11. Jack C
12. Jack B
13. Jack A
14. Fire Extinguisher
15. Head Light
16. Rear Fender A
17. Unnecessary
18. Rear Fender B
19. Muffler C
20. Muffler D
21. Muffler A
22. Muffler B
23. Unnecessary
24. Tail Light
25. Shovel
26. Wrench
27. Spare Wheel B
28. Hook
29. Fender Part A
30. Fender Part B
31. Spare Tracks Holder
32. Muffler Support
33. Rear Panel Upper
34. Rear Panel Lower
35. Shaft Bearing Part A
36. Cap
37. Spring A
38. Spring B
39. Shaft Bearing Part B Right
40. Shaft Bearing Part B Left
41. Rear Hook B
42. Rear Hook A Left
43. Rear Hook A Right
44. Front Hook A

C PARTS

1. Driver's Hatch
2. Gunner's Hatch B
3. MG-42
4. Spare Wheel Rack B
5. Spare Wheel Rack A
6. Spare Wheel Rack D
7. Front Shield
8. Holster
9. Periscope
10. Tool Box
11. Spare Track A
12. Spare Track B
13. Gunner's Shield
14. Spare Wheel Rack C
15. Figure-Body
16. Figure-Right Hand
17. Figure-Left Hand
18. Antenna Post A
19. Antenna Post B
20. Tag Rope
21. Gun Barrel Base
22. Rear Fender Right
23. Rear Fender Left
24. Gunner's Hatch A
25. Shaft Bearing
26. Canvass
27. Gun Barrel A
28. Gun Barrel B
29. Handle
30. Support Pin
31. Shaft
32. Range Finder Leg
33. Range Finder
34. Flap
35. Commander's Hatch
36. Cupola
37. Handrail
38. Figure Base
39. Jack Mount
40. Sight
41. Ventilator
42. Cleaning Rod
43. Hook Stopper
44. Hook

D PARTS

1. Armour Plate Rack Left
2. Armour Plate Hook D
3. Armour Plate Left
4. Armour Plate Rack Stay B
5. Armour Plate Rack Stay A
6. Front Balletproof Block
7. Driver Balletproof Block
8. Armour Plate Rack C
9. Armour Plate Rack A
10. Headphone
11. Armour Plate Right
12. Armour Plate Bracket
13. Armour Plate Hook B
14. Armour Plate Rack Right



- *Study the instructions and photographs before commencing assembly.
- *You will need a sharp knife, a pair of pliers, a file, and a pair of tweezers.
- *Vor Beginn die Bauanleitung studieren und den Nummern nach die Elemente zusammenbauen.
- *Kleine Teile hält man mit Pinzette fest.

A Part

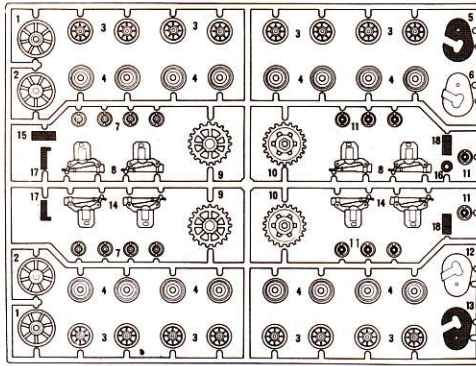

B Part

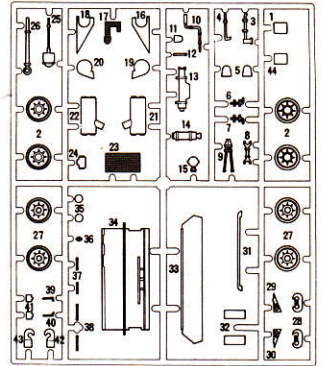

C Part

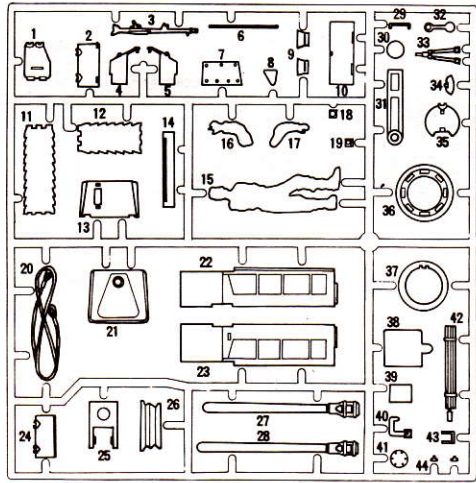

D Part

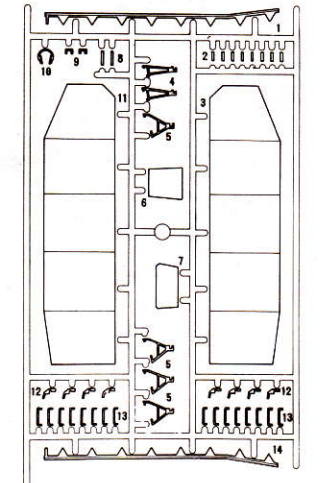

1 Construction Wheels Zusammensetzung der Räder

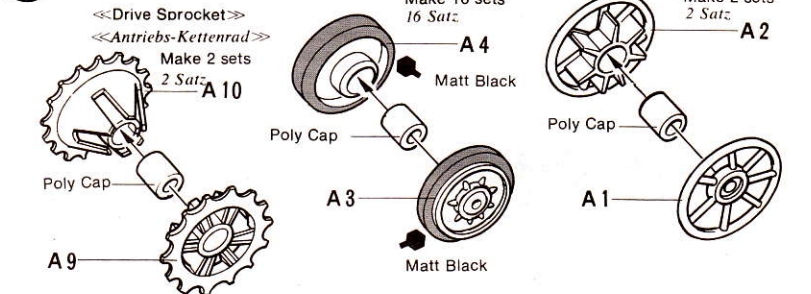

2 Construction of Rear Panel Construction der Heckverkleidung

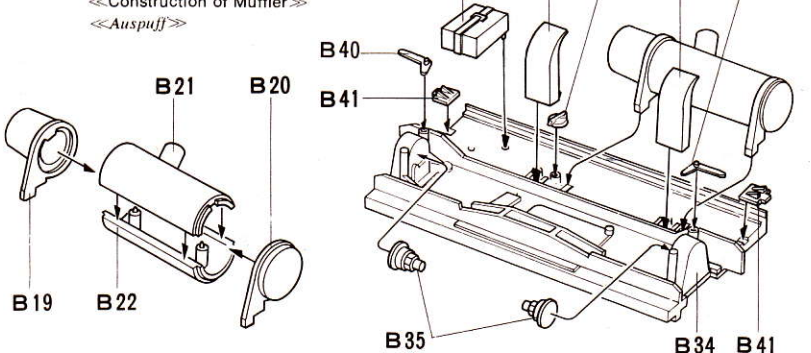

3 <<Fixing of Suspension>>
<<Radaufhängung>>

<<Support Rollers>>
<<Tragrollen>>

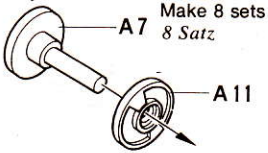

<<Reference Illustration of Assembling Front Panel>>
<<Teilansicht der Frontplatte>>

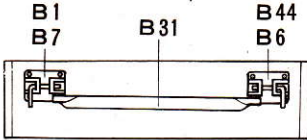

4 <<Fixing of Wheels>>
<<Radeinbau>>

Each wheels do not cement. Just insert.
Räder nicht kleben—nur einstecken.

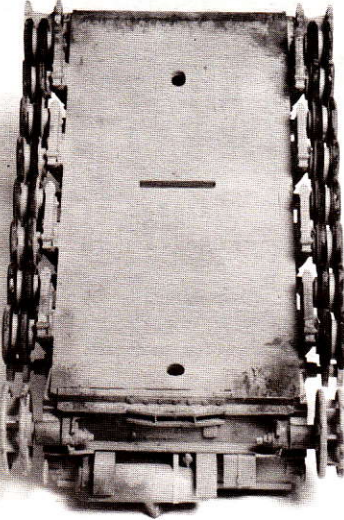

6 <<Construction of Upper Hull>>
<<Deckaufbauten>>

Gun Barrel is designed to move up and down, right or left.
Kanonenrohr ist beweglich nach oben, unten, links oder rechts.

<<Construction and Painting of Figures>>
<<Männchenbau>>

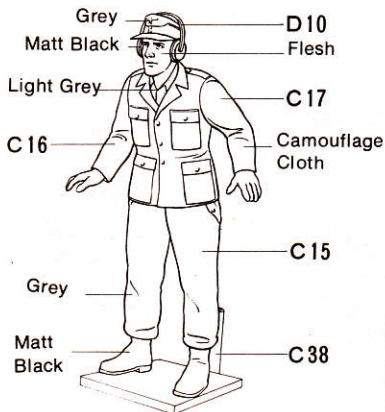

3 Fixing of Suspension
Einbau der Radaufhängung

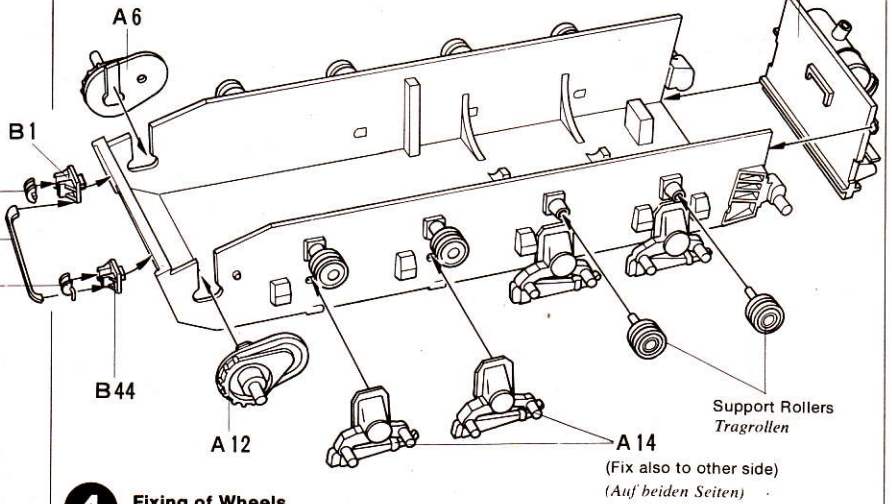

4 Fixing of Wheels
Radeinbau

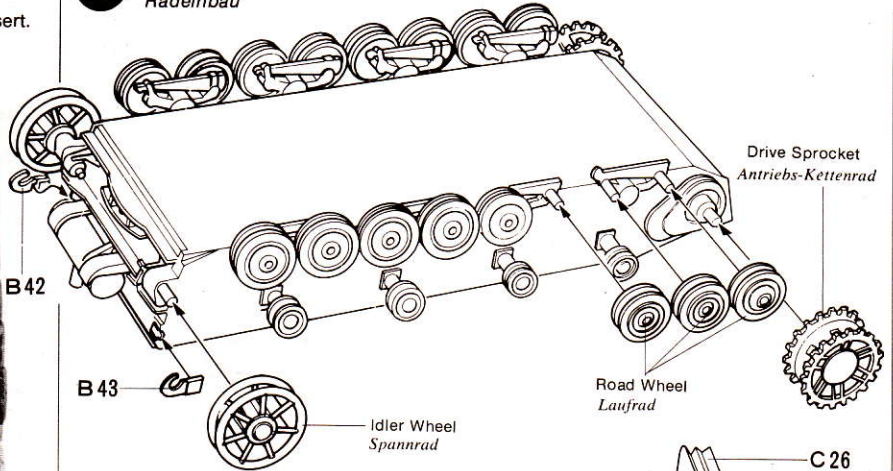

5 Construction of Gun Barrel
Construction der Kanone

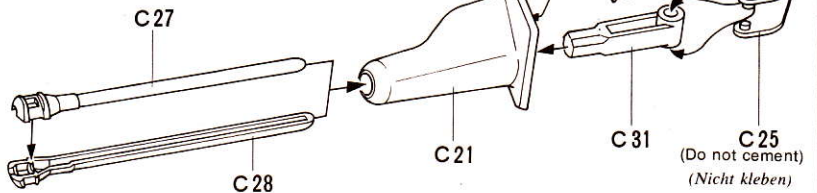

6 Construction of Upper Hull
Construction der Deckaufbauten

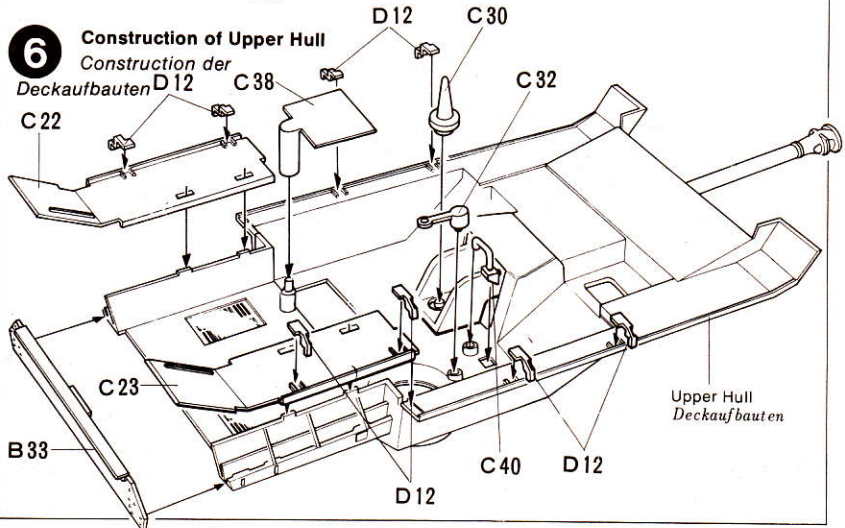

7 <<Fixing of Upper Hull Parts A>>
<<Einbau der Deckaufbauten A>>

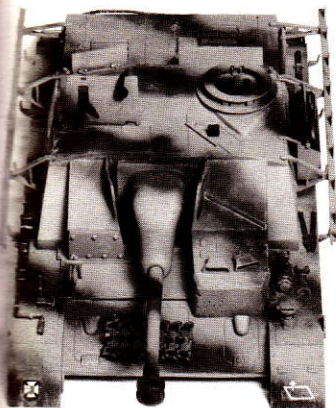

7 Fixing of Upper Hull Parts A
Einbau der Deckaufbauten A

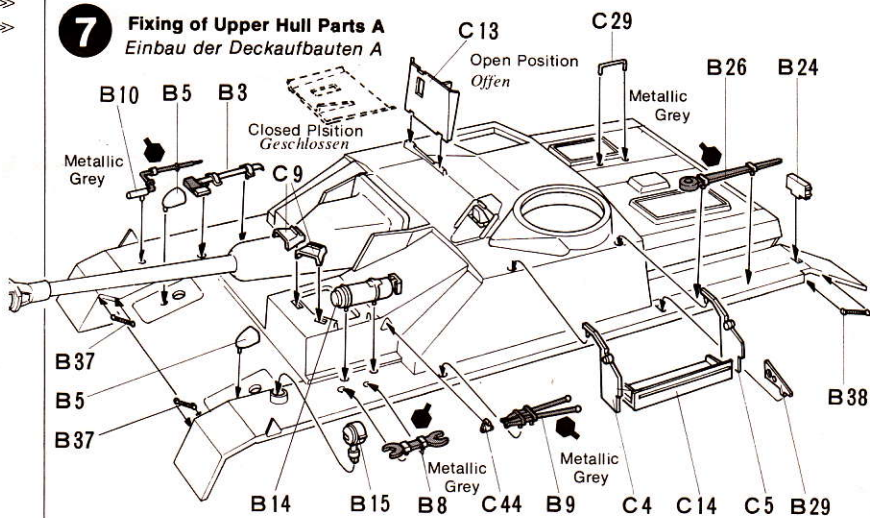

8 <<Construction of Hook and Cupola>>

<<Construction der Haken und Kuppel>>

Cupola can be fixed either in open or closed position

Kuppel-offen oder geschlossen einbauen

8 Construction of Hook and Cupola
Construction der Haken und Kuppel

<<Hook>> <<Haken>>

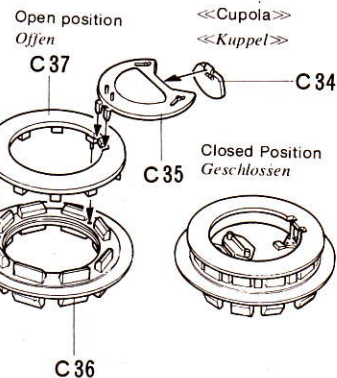
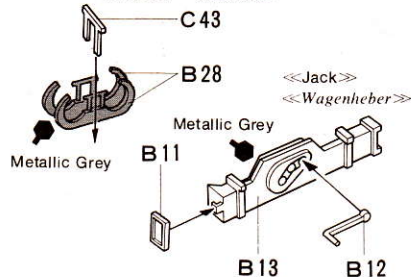

9 <<Fixing of Upper Hull Parts B>>
<<Einbau der Deckaufbauten B>>

<<Spare Wheel>>
<<Ersatzrad>>

Make 4 sets 4 Satz

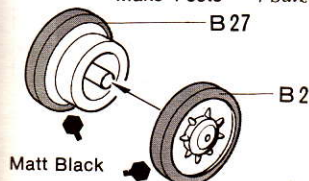

9 Fixing of Upper Hull Parts B
Einbau der Deckaufbauten B

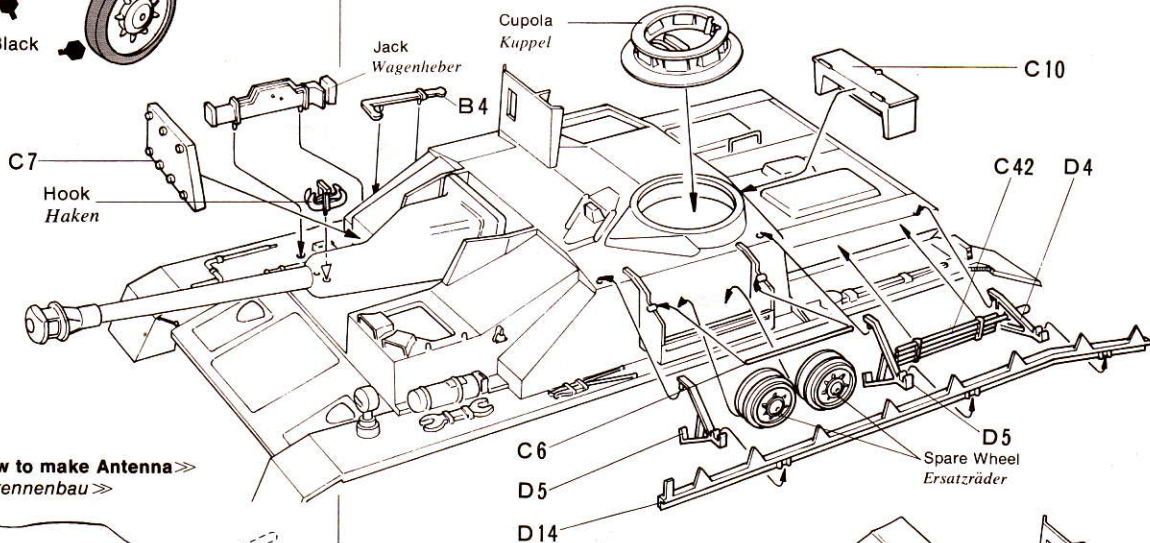

<<How to make Antenna>>
<<Antennenbau>>

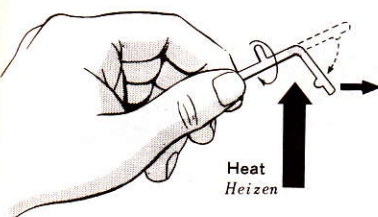

<<Fixing of Bulletproof Cement Block>>
<<Kugelsicherer Zementblock>>

Do not fix C7 and Hook when cement block will be used.
Platte C7 und den Haken nicht einbauen, wenn Zementblock eingesetzt wird.

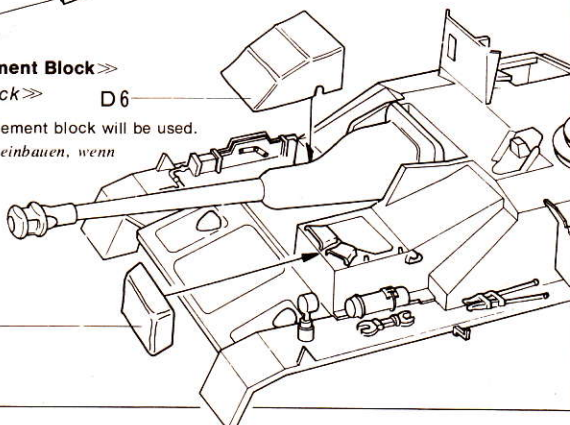

TAMIYA COLOR CATALOGUE

The latest in cars, boats, tanks and ships. Motorized, radio controlled and museum quality models are all shown in full color in Tamiya's latest catalogue. At your nearest hobby supply house.

10 <<Fixing of Upper Hull Parts C>>
<<Einbau der Deckaufbauten C>>

If you prefer to put Commanders Figure, fix C2, C24 in an open position.

Bei Einsatz des Kommandanten C2, C24 offen einbauen.

<<Open Position>>

<<Offen>>

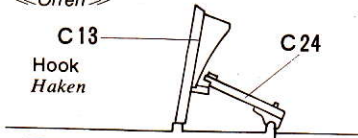

<<Closed Position>>

<<Geschlossen>>

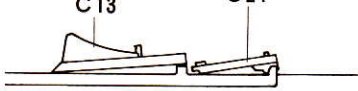

13 <<Completion>>
<<Endmontage>>

Do not cement but just insert armour plates stays into pins on the fender.

Fertiges Schürzen nur in die Haken einhängen

<<Fixing of M. G.>> <<Einbau der M.G.>>

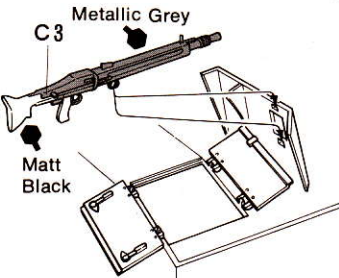

<<Connection Tracks by Heating>>

<<Kettenmontage>>

Melt pin heads with a head screwdriver and immediately after that, press pin heads.

Zapfenkopf mit heissem Schraubenzieher

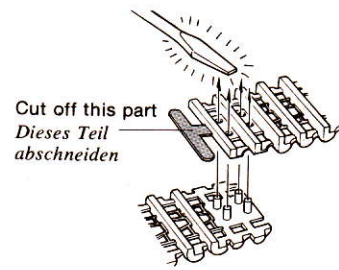

Cut off this part
Dieses Teil abschneiden

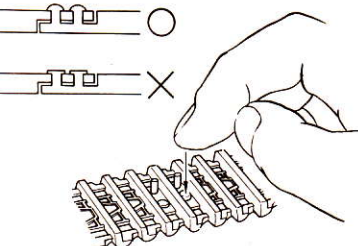

If track broken, strengthen with staplers, or thread

Bei Kettenbruch mit Hefklammer oder Draht flicken

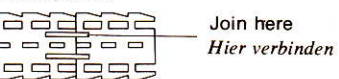

10 Fixing of Upper Hull Parts C
Einbau der Deckaufbauten C

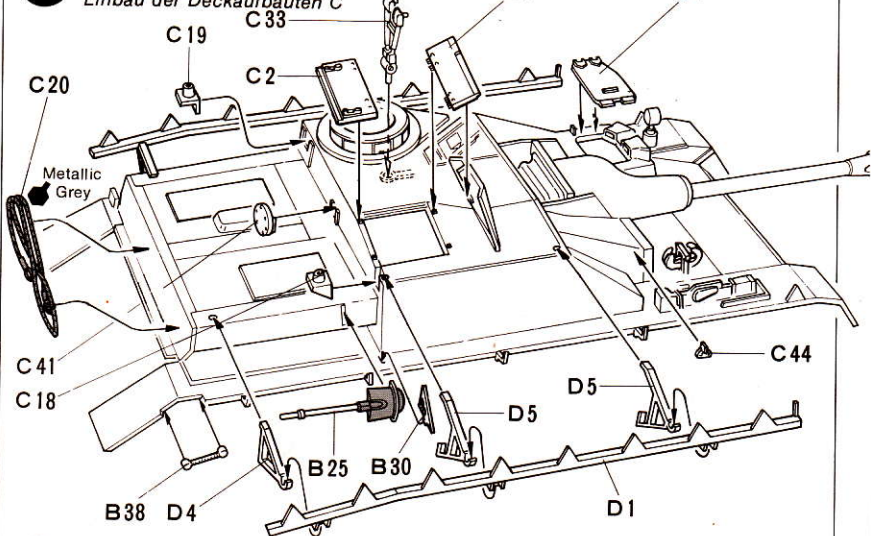

11 Construction of Armour Plates
Bau der Panzerschürzen

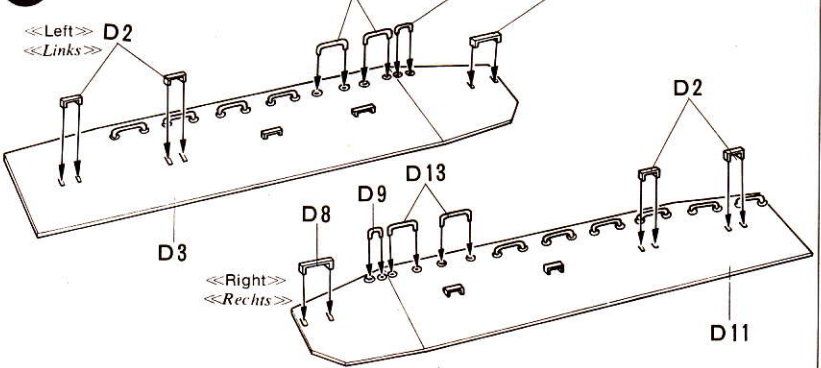

12 Completion
Endmontage

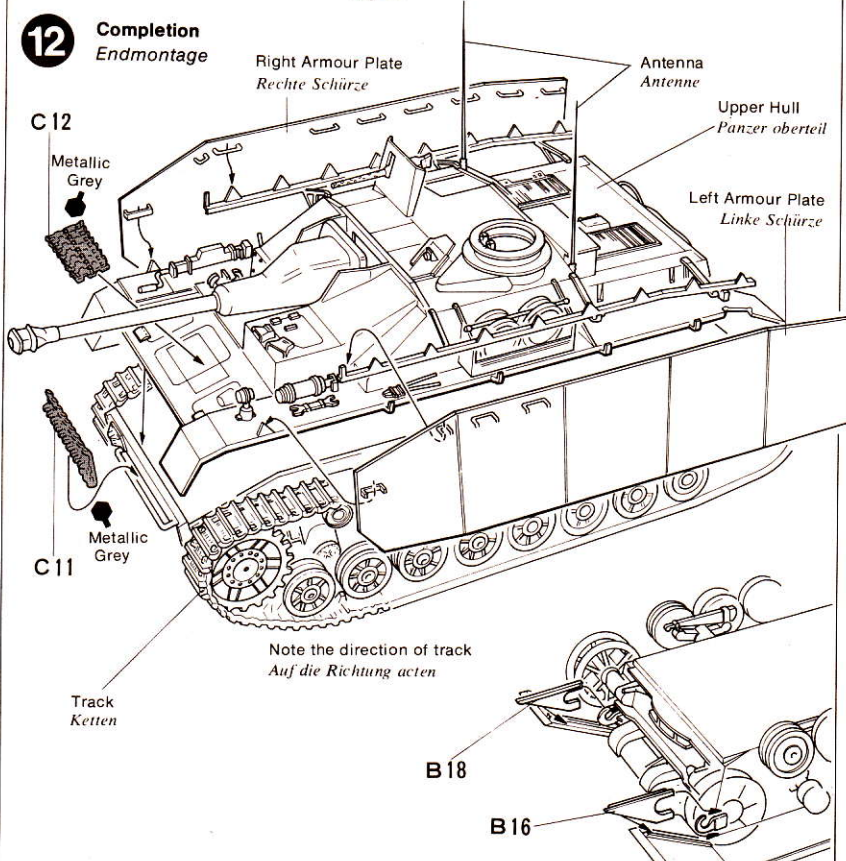

PAINTING



APPLYING DECALS

<<Painting of the Sturmgeschütz IV>>

<<Bemalung des Sturmgeschütz IV>>

The Sturmgeschütz IV was detailed at the end of 1943. On 18th February of that year, the German Army authorities ordered to use dark yellow as the basic colour of vehicles in place of German grey which had been used as such use until that time. Therefore, Sturmgeschütz IV was basically painted dark yellow. Field forces, however, often put other colours for camouflage on the basic colour according to the terrain of the battle field where they fought. There were no fixed camouflage patterns. They freely put red brown, and/or dark green on the basic colour by means of brushed or spray guns.

Der Sturmgeschütz kam Ende 1943 zum Einsatz. Am 18. Februar dieses Jahres wurde von der Heeresleitung die übliche graue Farbe durch das dunkelgelb ersetzt. Die Grundfarbe des Sturmgeschütz IV war deshalb dunkelgelb. Die Fronttruppen bemalten ihre Fahrzeuge noch zusätzlich nach Einsatzort - zur Tarnung mit dunkelbraun, rotbraun oder dunkelgrün.

<<Marking of Sturmgeschütz IV>>

	237th Assault Gun Brigade		Training Div.
	251th Assault Gun Brigade		2nd Panzer Div.
	279th Assault Gun Brigade		9th Panzer Div.
			Panzer Div.
	Tactics Mark		Takt. Zeichen
	Tactics Mark of Assault Howitzer IV		

BUILD A COLLECTION OF TAMIYA 1/35 SCALE TANK AND ARMORED CAR MODELS

1/35 U.S. M3 BRADLEY CFV

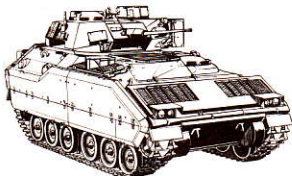

1/35 U.S. M2 BRADLEY IFV

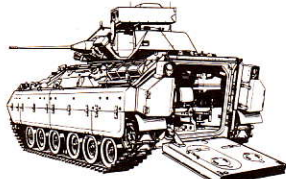

1/35 BRITISH MBT CHALLENGER

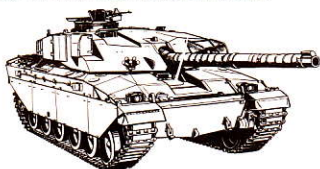

TAMIYA
TAMIYA PLASTIC MODEL CO.
628, OSHIKA, SHIZUOKA-CITY, JAPAN

<<Painting of the Sturmgeschütz IV>>

<<Bemalung des Sturmgeschütz IV>>

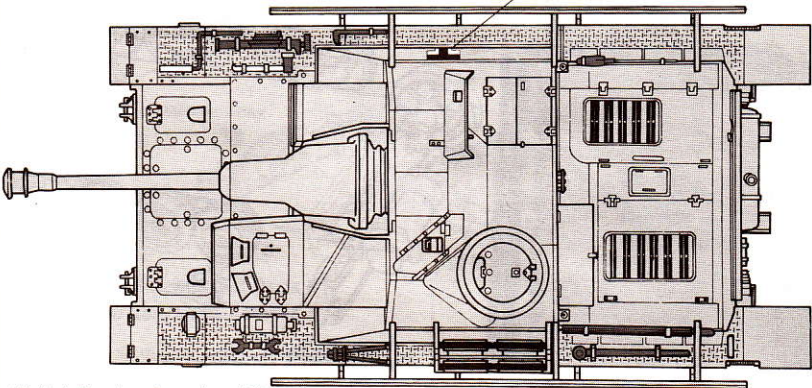
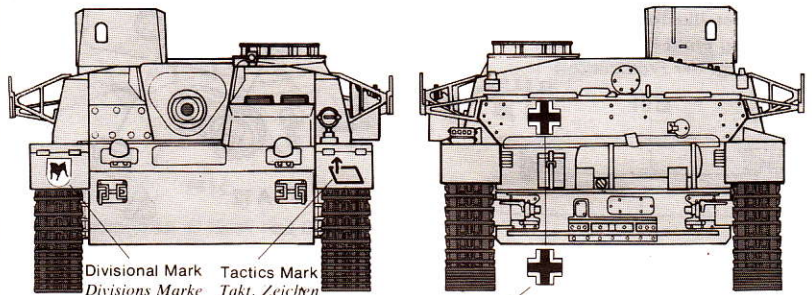
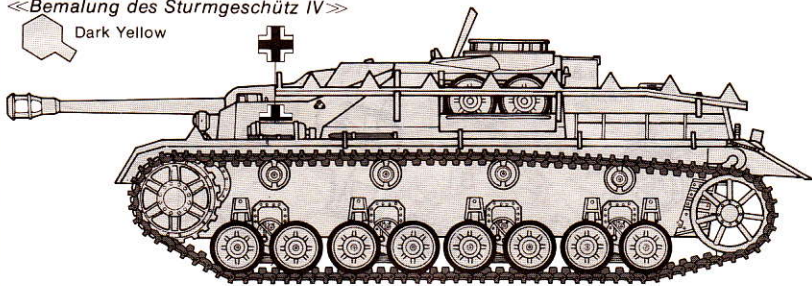

*Vehicle Number: A number of three figures

Fahrzeug-Nummer: Die dreistellige Zahl.

Example: 113 (1st Company, 1st Platoon, Number 3)

Beispiel: 113 (1 Kompanie, 1 Zug, Number 3)

